

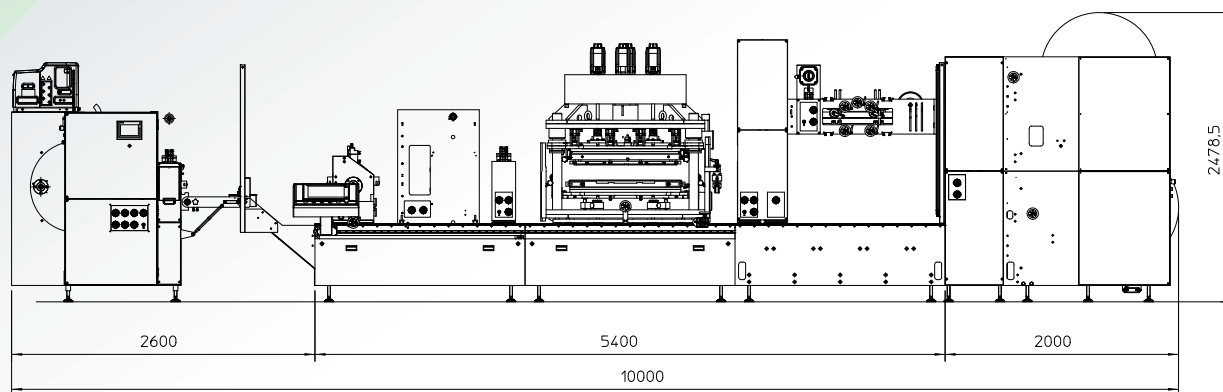

SA-M RW

Designed and engineered to produce flat
and gusset rolls for the medical market



ELBA



 The **SA-M RW** machine is flexible, technologically advanced, easy to use and capable of producing a wide range of high-quality rolls.

The **SA-M RW** machine can run with medical grade paper, Tyvek®, PET/PE, PA/PE, PET/PP or coextruded materials, both printed and unprinted, thus ensuring high performances and high reliable seals. Furthermore, some options are available to meet all customers' requirements and to offer them tailor-made solutions.

The **SA-M RW**, with its patented chevron sealing station, is offered in two different sealing widths, 650 mm [25.6"] and 950 mm [37.4"], thereby guaranteeing the production of any of the following products:

- Flat rolls
- Gusset rolls

The **SA-M RW** machine is fully equipped with Siemens components and it is entirely controlled by a state-of-the-art HMI based on Profinet®, one of the most advanced communication protocols. It controls each of the installed stations/tools independently and in real time and, consequently, the whole production process. Each station is independent, servo driven and plug & play.

The **SA-M RW** modular design allows the machine to be customized, according to different production requirements; the machine configuration can be upgraded at any time, to face new unpredictable market demands.

ELBA is always focused on its customers' needs and, as energy costs are expensive variables for all the manufacturers, the **SA-M RW** has been engineered with dedicated components that allow recovering the kinetic energy.

Moreover, the above-mentioned technology together with the innovative graphic interface enable the **SA-M RW** to offer different production cycles and a wide range of accessories dedicated to the process control:

- Vision system
- Fully customized data collection systems
- Automatic stations and tool positioning systems



		SA-M CH+RW 06	SA-M CH+RW 09
Useful sealing width	mm	640	940
Max. starting roll diam.	mm	1000	1000
Max. finish roll diam.	mm	300	300
Max. film speed	m/min	60	60



ELBA S.p.A.
Via Canova, 22 > 20020 MAGNAGO (MI) - Italy
Tel. +39 0331.305570 > Fax +39 0331.659820
sales@elba-spa.it > www.elba-spa.it

