

SA-M CH

Flexible and technologically advanced machines
for the production of high-quality medical pouches

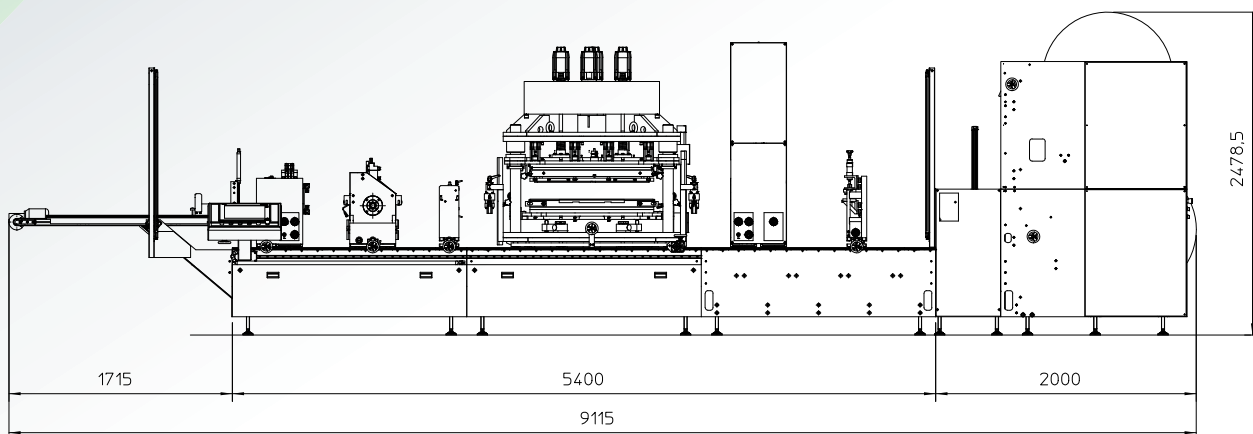

ELBA



The **SA-M CH** machine has been designed and engineered to produce high tech pre-made pouches for the medical and pharmaceutical markets.

All the **SA-M CH** machines can run with medical grade paper, Tyvek®, PET/PE, PA/PE, ALU, PET/PP or coextruded materials, both printed and unprinted, thus ensuring high performances and high reliable seals. A wide range of options is available to meet all customers' needs and to offer them tailor-made solutions.

The **SA-M CH**, with its patented chevron sealing station, is offered in two different sealing widths, 650 mm (26.6") and 950 mm (37.4"), thereby guaranteeing the production of any of the following pouches (according to the configuration):

- Three side seal pouches
- Chevron pouches
- Gusseted chevron pouches
- Self-sealing pouches
- Patch pouches

The **SA-M CH** machine is fully equipped with Siemens components and it is entirely controlled by a state-of-the-art HMI based on Profinet®, one of the most advanced communication protocols. It controls each of the installed stations/tools independently and in real time and, consequently, the whole production process. Each station is independent, servo driven and plug & play.

The **SA-M CH** modular design allows the machine to be customized, according to different production requirements; the machine configuration can be upgraded at any time, to face new unpredictable market demands.

ELBA is always focused on its customers' needs and, as energy costs are expensive variables for all the manufacturers, the **SA-M CH** has been engineered with dedicated components that allow recovering the kinetic energy.

Moreover, the above-mentioned technology together with the innovative graphic interface enable the **SA-M CH** to offer different production cycles and a wide range of accessories dedicated to the process and the validation control:

- Vision system
- Fully customized data collection systems
- Automatic stations and tool positioning systems

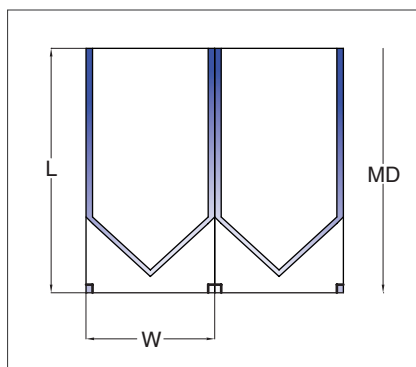

| | | SA-M CH 06 | SA-M CH 09 |
|-----------------------|-------|------------|------------|
| Useful sealing widths | mm | 640 | 940 |
| Max. roll diam. | mm | 1000 | 1000 |
| Max. film speed | m/min | 80 | 80 |



ELBA S.p.A.

Via Canova, 22 > 20020 MAGNAGO (MI) - Italy
Tel. +39 0331.305570 > Fax +39 0331.659820
sales@elba-spa.it > www.elba-spa.it

